

MAZDA MOTORSPORTS

By: **PENSKE**
RACING SHOCKS

RX8 NON-ADJUSTABLE REAR SHOCK, P/N: 0000-04-5292-RX
REQUIRED REAR UPPER MOUNT KIT, P/N: 0000-04-8358-MT

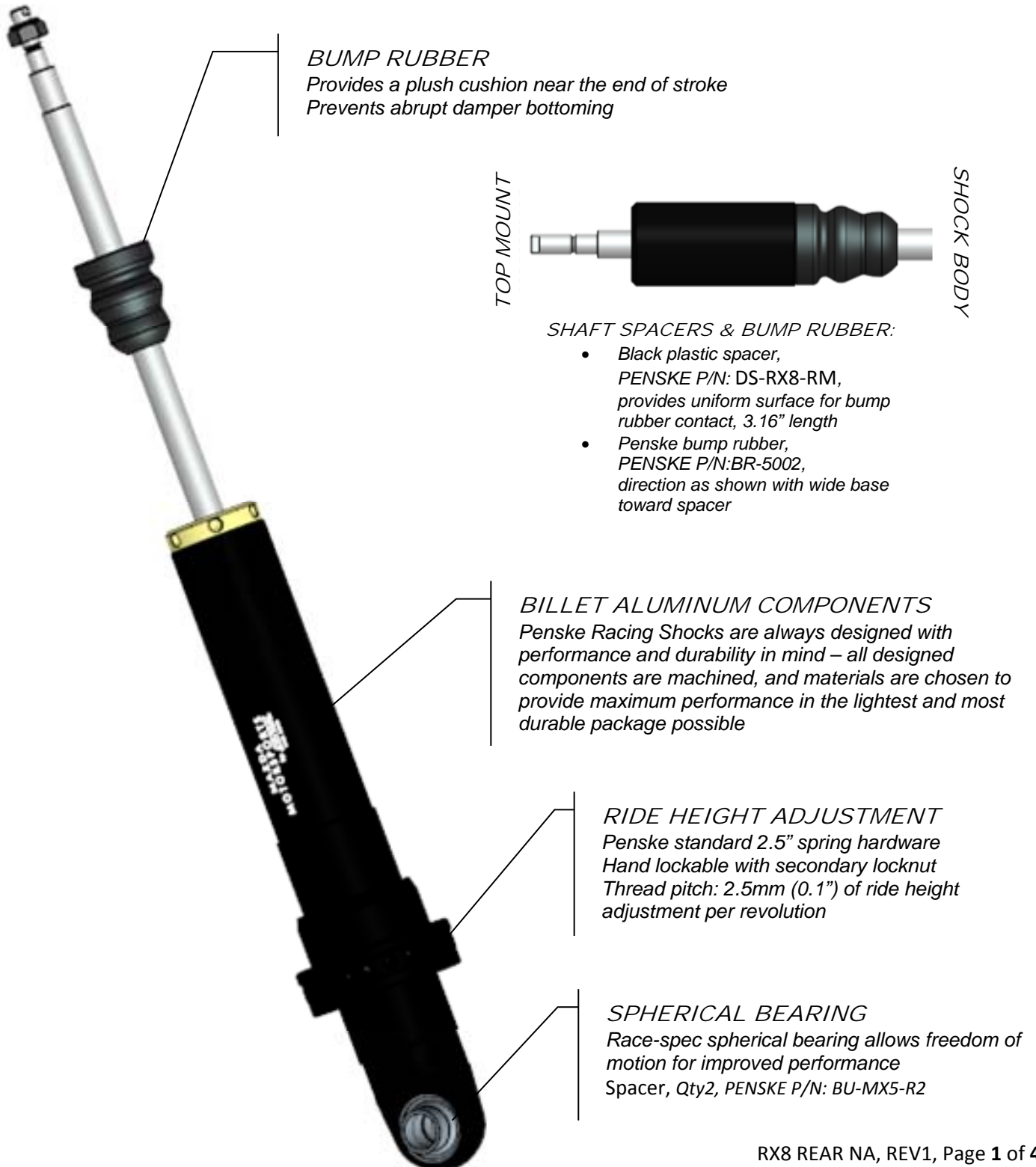

MAZDA MOTORSPORTS

By: **PENSKE**
 RACING SHOCKS

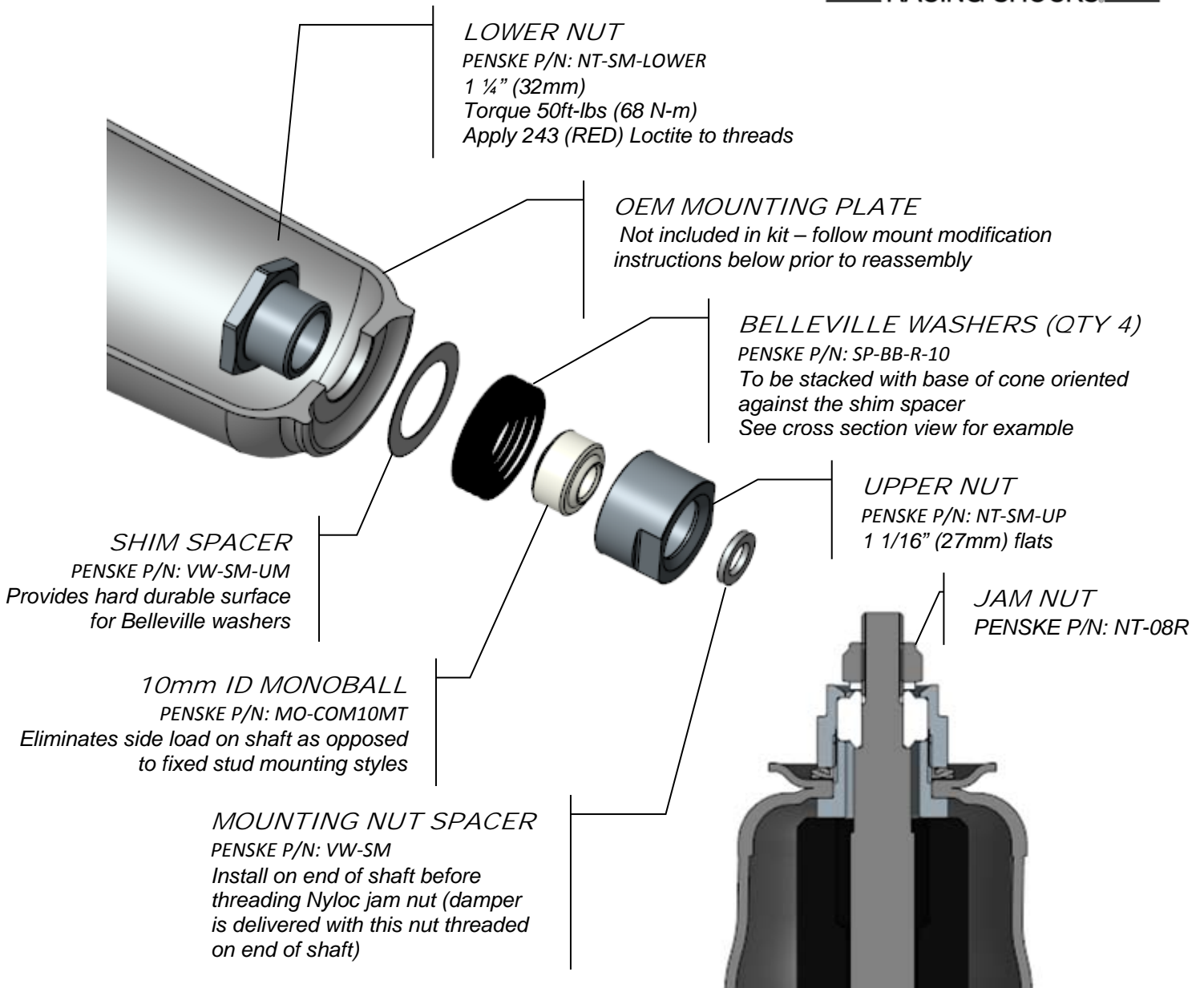

TOP MOUNT MODIFICATION:

1. Remove mount from vehicle
2. Secure mount to table of drill press/mill
3. Using high speed step drill bit & cutting fluid, enlarge existing thru hole to $\varnothing.938$ (15/16"). (Step drill can be purchased from any industrial supplier such as McMaster-Carr, MSC, Grainger, etc.)
4. Chamfer/deburr hole edges
5. Assemble mounting components as specified above
6. Re-install into vehicle

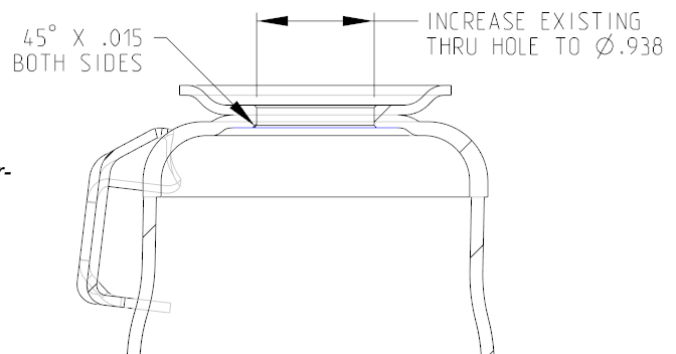

MAZDA MOTORSPORTS

By: **PENSKE**
RACING SHOCKS

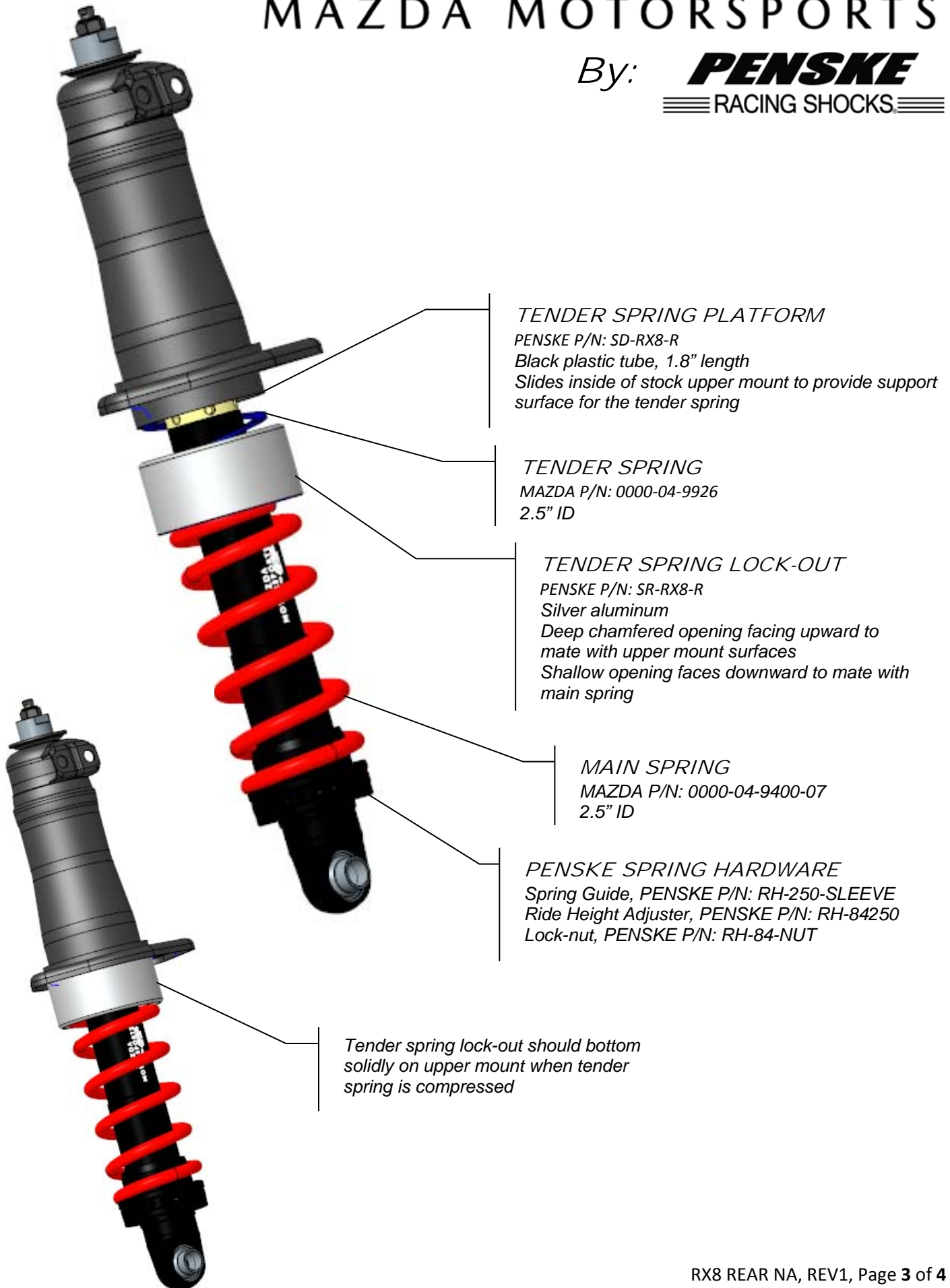

MAZDA MOTORSPORTS

By: **PENSKE**
RACING SHOCKS

REAR SHOCK SPACING

This picture shows improper spacing of the lower shock mount. The proper spacing procedure requires the user to install the rear dampers without springs and take the suspension through its full travel to confirm that the shock is centered within the mount. This procedure must be completed after the racecar has been properly aligned to achieve race settings (Camber). Improper spacing will likely cause binding of the suspension, and a loss of performance.



PROPER SPACING

This picture shows the proper spacing of the lower shock mount.

PENSKE
RACING SHOCKS

150 FRANKLIN ST
READING, PA 19602
(610) 375-6180 • (610) 375-6190 FAX